

NOTE: MAKE SURE TO APPLY A STRIPE OF GLUE AND PRIMING OF 2 INCHES IN LOCATION 1 AND 2.

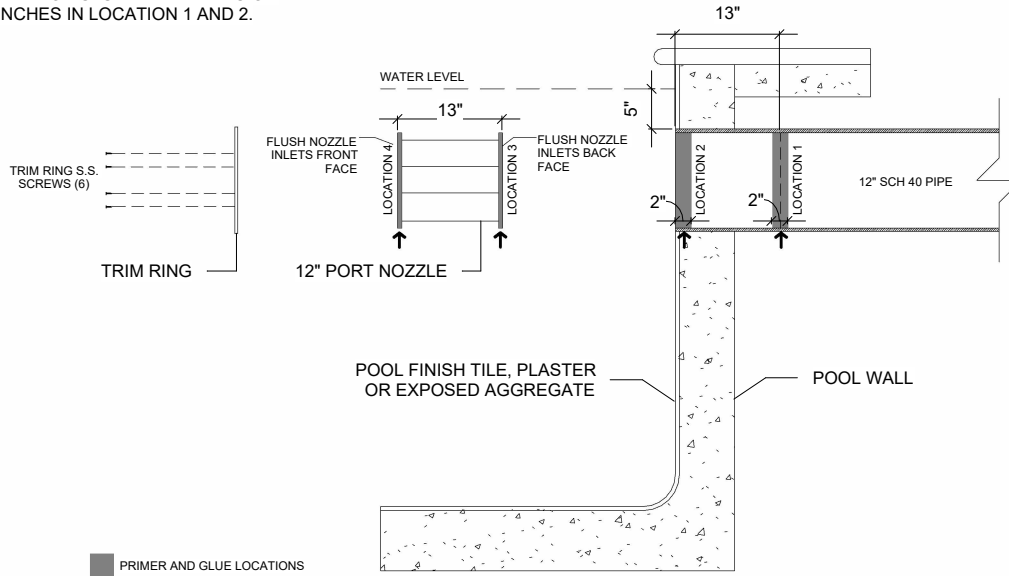

STEP 1. NOZZLE FACE IDENTIFICATION

A NOZZLE WITH A COVER PLATE WILL HAVE A **FRONT AND A BACK FACE** THE FRONT FACE HAS ALL PIPES CUT FLUSH WITH "NON-RADIUS" ON THE PIPES. THE FRONT FACE IS WHERE THE COVER PLATE WILL ATTACH TO. THE BACK FACE OF THE NOZZLE WILL HAVE A RADIUS ON THE INLET OF EACH PIPE. THE BACK FACE WILL ALSO BE INSTALLED FURTHEST INTO THE PIPE.

STEP 2. PREPARATION

BEFORE APPLYING ANY PRIMER OR GLUE PLEASE TEST FIT NOZZLE INTO THE PIPE. THE NOZZLE SHOULD SLIDE INTO THE PIPE WITHOUT BEING FORCED. IF THE NOZZLE DOES NOT FIT; SAND OFF A SMALL AMOUNT OF THE FRONT AND REAR EDGES TILL THE NOZZLE SLIDES IN THE PIPE. MAKE SURE ALL SURFACES ARE CLEAN AND FREE OF DEBRIS BEFORE ANY PRIMER OR GLUE IS APPLIED.

STEP 3. PRIMER AND GLUING

MEASURE 13 INCHES DEEP INTO THE OPENING OF THE PIPE AND APPLY PRIMER AND GLUE TO "PRIMER AND GLUE LOCATION 1 AND PRIMER AND GLUE LOCATION. NEXT APPLY PRIMER AND GLUE "PRIMER AND GLUE LOCATION 3 AND PRIMER AND GLUE LOCATION 4". INSERT NOZZLE INTO THE PIPE SO THE 3 LARGER HOLES ARE HORIZONTAL. ONCE THE NOZZLE HAS BEEN FULLY INSERTED IN THE PIPE AND IS FLUSH WITH THE PIPE OUTLET, ROTATE THE NOZZLE LEFT AND RIGHT TO MAKE SURE IT HAS A GOOD COATING OF GLUE. BE SURE THE NOZZLE HAS BEEN PROPERLY SET.

STEP 4. TRIM RING INSTALLATION

ALIGN ALL HOLES ON THE TRIM RING WITH THE MATCHING HOLES ON THE NOZZLE. THE FLAT SURFACE WILL BE ATTACHED TO THE NOZZLES FLAT SURFACE. ONCE ALL HOLES ARE ALIGNED, DRILL 1/8 INCH PILOT HOLES FOR ALL 6 SCREW LOCATIONS. FINALLY, ATTACH THE TRIM RING TO THE NOZZLE WITH THE INCLUDED STAINLESS-STEEL SCREWS.

1 7 PORT NOZZLE INSTALLATION
1/2" = 1'-0"

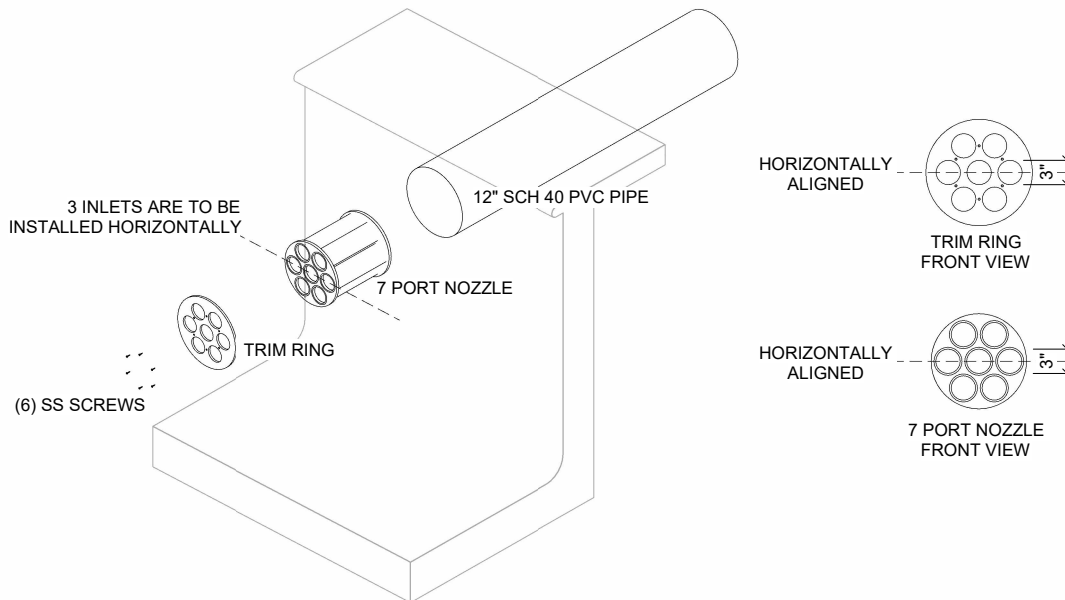

2 INSTALLATION ISOMETRIC VIEW

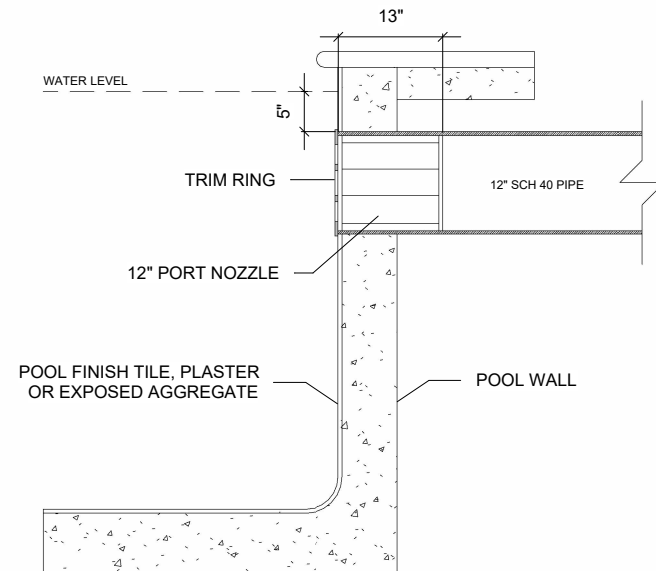

3 INSTALLED 7 PORT NOZZLE
1/2" = 1'-0"

SHEET TITLE:
INSTALLATION DETAILS

PROJECT NAME:
7 PORT NOZZLE / TRIM RING
INSTALLATION



ISSUE DATE:
01/11/2024
DRAWN BY:
MA
CHECKED BY:
PD

PAGE NUMBER:
D101